

## Smartscreen Motorized Mosquito Screen

It is the most versatile motorized system on the market. Protect views up to 8 meters long. Enjoy your environments in a comfortable and expanded way with the single touch of a button!

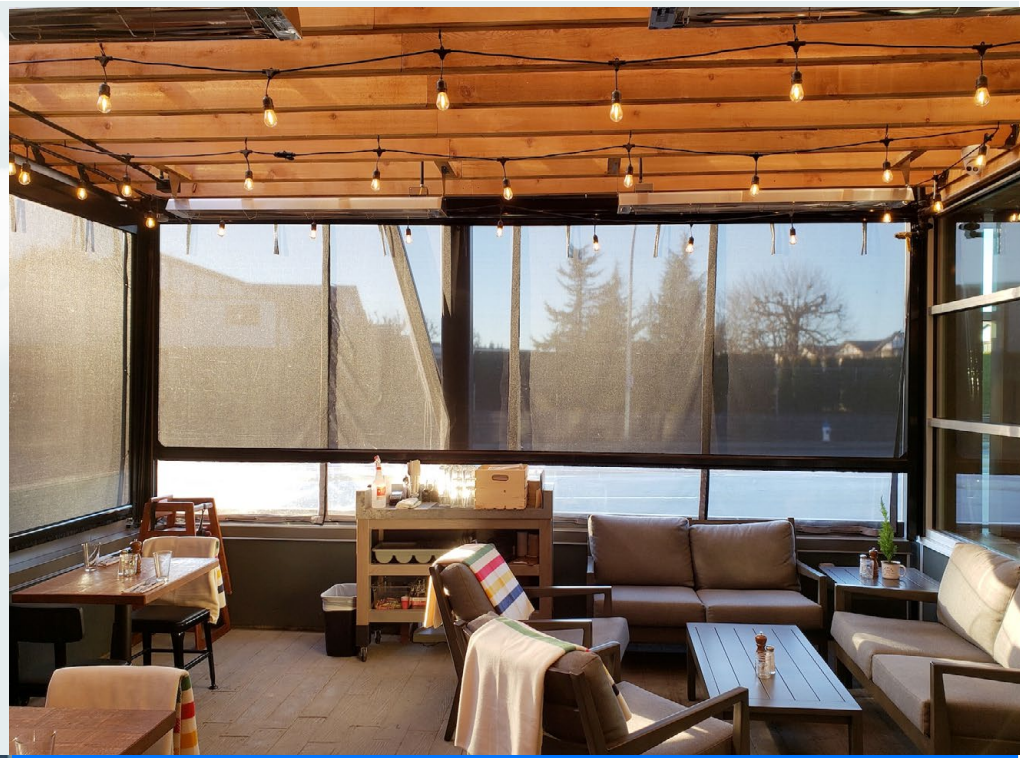

**SmartScreen motorized mosquito screen is an innovative system with the highest performance. Is an avant-garde luxury product designed for maximum comfort.**

Thanks to its engineering and design, retracts at your choice. Its lateral retention technology keeps the mesh fixed on the rails. At the push of a button, you control your outdoor spaces, protecting them against insects and weather changes. The SmartScreen is fantastic for patios, decks, gardens, garages, windows, outdoors, shops, and restaurants.

### Benefits

- Automated control of your environments.
- Keep insects under control.
- Provide privacy.
- Control the passage of sun and shade.
- Reduce the passage of UV rays.
- You enjoy your spaces with comfort.
- Provide ventilation.

### Features

- Lateral retention that keeps the mesh fixed on the tracks.
- Integrated brushes for self-cleaning.
- The screen is embedded and integrated into the structure of the space.
- Silent refraction & maximum adjustment eliminates screen vibration.
- Operation with sun/wind sensor and from a smartphone.
- Different remote control options.
- Somfy motors with lasting duration and performance.
- Discreet, elegant, and modern design. Harmonious integration to any architecture.
- The screen disappears from view when not in use.
- Professional installation by our experts.

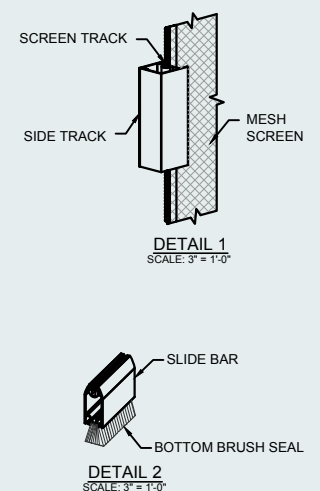
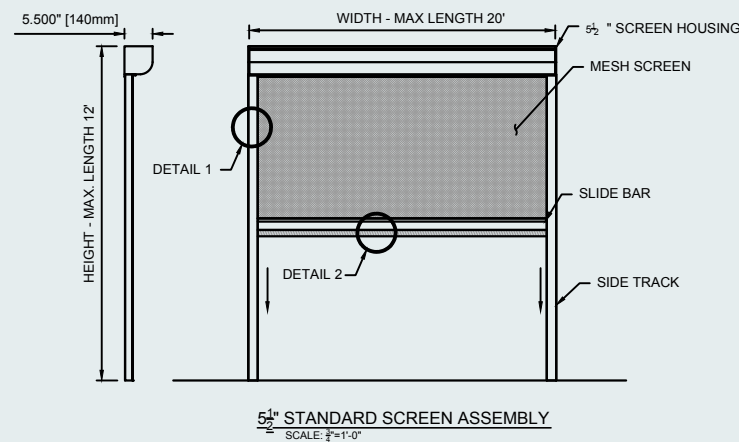
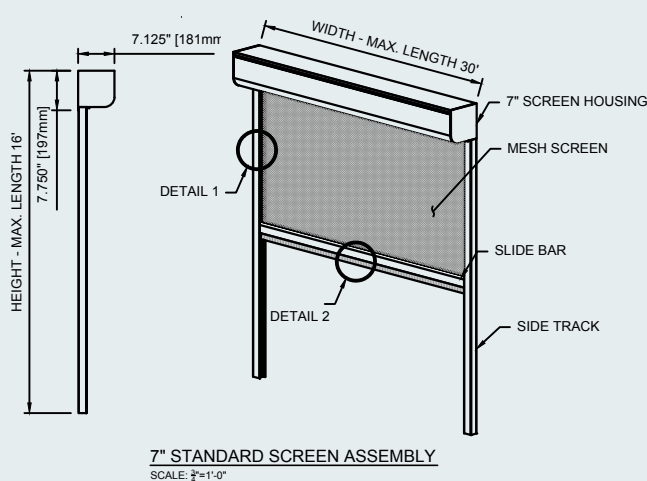

### finishes

#### Electrostatic painting

- Black
- White
- Ivory

### Tamaños

Up to  
9 m wide and 4.8 m in height.

Discover more about SmartScreen.

More

We are innovators and industry leaders with over 15 years of experience. We manufacture, distribute and install high-quality and international standard pergola systems in all of Mexico.